



Printed Pages : 3

CE – 031

(Following Paper ID and Roll No. to be filled in your Answer Book)

PAPER ID : 0036

Roll No.

--	--	--	--	--	--	--	--	--	--

B. Tech.

(SEM. VIII) EXAMINATION, 2006-07

ADVANCED CONCRETE DESIGN

Time : 3 Hours]

[Total Marks : 100

- Note : (1) Attempt *all* questions.
(2) All questions carry *equal* marks.

1 Attempt any **two** parts of the following : **10×2=20**

- a) Design middle ring beam, balcony and vertical wall for an intze type tank shown in figure 1

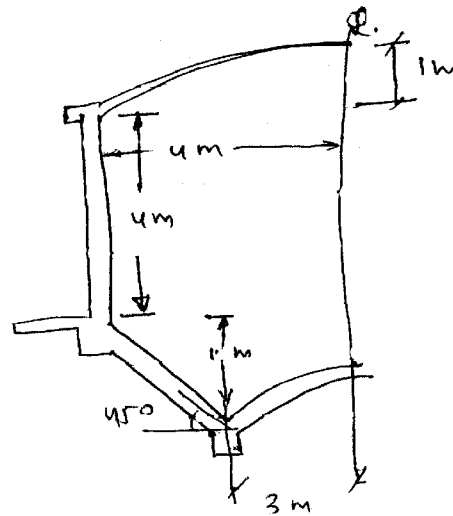

Fig. 1

- b) Design the top dome, top ring beam and vertical wall for circular overhead tank shown in figure 2.

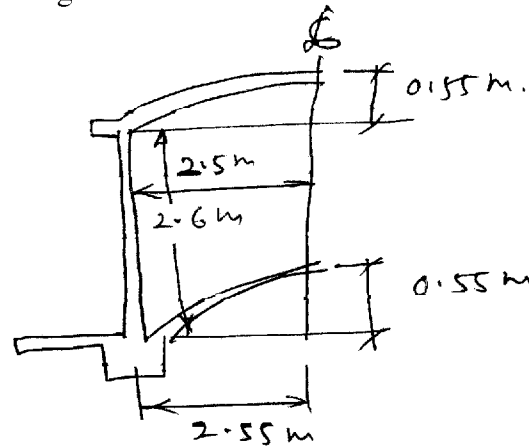

Fig. 2

- c) Design a ring beam of size 300×500 mm supported by columns of 300 dia and subjected to a load of 55 kN/m. Dia of staging is 5.0 m and HT in ring beam is 100 km. The co-efficient for BM are as given below :
- ve BM = $0.137 WR^2(2\theta)$
+ve BM = $0.07 WR^2(2\theta)$
torsion BM = $0.021 WR^2(2\theta)$

2 Attempt any **two** parts of the following : **10×2=20**

- a) Explain in detail how wind load is calculated in overhead water tanks.
- b) Explain how horizontal load causes BM in columns and Bracer of staging.
- c) Design an annular raft foundation for following data :

c/c dia of staging - 12.0m
BC of soil - 100 kN/m²
Total load at Base - 16000 kN
Windmount at Base - 4600 kN-M

3 Attempt any **two** parts of the following : **10×2=20**

- a) Explain the portal method of analysis for building frame.
- b) Explain the cantilever method of analysis for building frame.
- c) Discuss substitute frame method for analysis of building frames.

4 Attempt any **two** parts of the following : **10×2=20**

- a) Discuss the Pigeand's method for finding out moment in a slab due to concentrated load.
- b) Discuss Courban's method of load distribution in longitudinal grades.
- c) Design a slab bridge for clam AA (tracked) vehicle loading for the following data.

Clean span = 4.5 m

Clean width of roadway = 7.0 m

Use M-25 concrete and HYSD 415 bars.

5 Attempt any **four** of the following : **4×5=20**

- i) High performance concrete
- ii) High strength concrete
- iii) Self compacting concrete
- iv) Composite construction
- v) Polymer concrete
- vi) Fire reinforced concrete.